

OmegaScope™

The AFM Optical Platform



Resolution

High resolution and stability



Automation

Automated operation, easy to use



SPM Modes

All SPM modes included



Upgradability

Top and side optical access

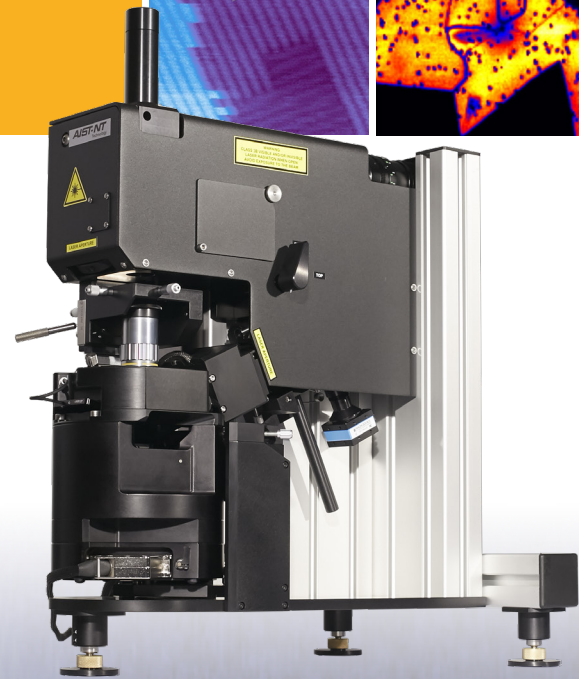

Scanning Probe Microscope Series

OmegaScope Measuring Modes	
Basic modes:	<ul style="list-style-type: none"> • Contact AFM • Semicontact AFM • True Non-contact AFM • Top Mode™ • Phase Imaging • Dissipation Force Microscopy • Contact AFM in liquid (optional) • Semicontact AFM in liquid (optional)
Electrical modes:	<ul style="list-style-type: none"> • Single / Double pass Kelvin Probe Force Microscopy (KPFM) AM and FM • Capacitance Microscopy (SCM) • Single / Double pass Electric Force Microscopy (EFM) • Piezo Response Force Microscopy (PFM) • PFM with High Voltage (optional) • PFM-Top mode™ • Conductive AFM (optional) • Conductive AFM High Voltage (optional) • I-Top mode™ (optional) • I-V Spectroscopy (optional) • Photocurrent Mapping (optional) • Volt-ampere characteristic measurements (optional)
Nanomechanical modes:	<ul style="list-style-type: none"> • Lateral Force Microscopy (LFM) • Force Modulation Microscopy (FMM) • Force Curve Measurement (Force Distance (F-D) Spectroscopy and Mapping) • Nanolithography • Nanomanipulation
Nanospectroscopy:	<p>Compatible with HORIBA spectrometers (XploRA, LabRAM HR, LabRAM Soleil) (optional)</p> <ul style="list-style-type: none"> • Confocal Raman, Photoluminescence imaging and spectroscopy (optional) • Tip-Enhanced Raman and Photoluminescence (TERS/TEPL) (optional) • Near-field Scanning Optical Microscopy (NSOM/SNOM), with fiber-based and cantilever-based SNOM probes (optional)
Special modes:	<ul style="list-style-type: none"> • Single / Double pass Magnetic Force Microscopy (MFM) • Tunable Magnetic Field (optional) • Shear-force Microscopy with tuning fork (ShFM) • Normal-force Microscopy with tuning fork (optional)
Other:	<ul style="list-style-type: none"> • Scanning Tunneling Microscopy (STM) (optional) • Scanning Tunneling Spectroscopy (optional)

OmegaScope Scanner and Base	
Sample scanning range:	100 x 100 x 15 μm^3 (+/-10%)
Non-linearity:	XY < 0.05%, Z < 0.05%
Noise:	<ul style="list-style-type: none"> • < 0.1 nm RMS in XY dimension in 100 Hz bandwidth with capacitance sensors on • < 0.02 nm RMS in XY dimension in 100 Hz bandwidth with capacitance sensors off • < 0.1 nm RMS in Z dimension in 1000 Hz bandwidth with capacitance sensor on • < 0.03 nm RMS in Z dimension in 1000 Hz bandwidth with capacitance sensor off
Resonance frequency:	XY: 7 kHz (unloaded); Z: 15 kHz (unloaded)
Open loop XY drift:	< 0.5 nm / min
Motorized approach range:	17 mm
Maximum sample size:	40 x 50 mm ² , 15 mm thickness
Sample positioning: Motorized sample positioning range:	5 x 5 mm ²
Motorized approach range:	17 mm

OmegaScope AFM Head	
Laser wavelength:	1300 nm No influence of registration laser on photovoltaic measurements or on biological samples Avoid optical interferences for Raman application
Fully motorized:	4 stepper motors for automatic cantilever and photodiode alignment
Access:	Free access to the probe for additional external manipulators and probes
Illumination:	Illumination intensity is software controlled

OmegaScope Optical Access	
Top/side optical access:	Simultaneous use of top and side plan apochromat objectives – Up to 100x, NA = 0.7 from top or side / Up to 20x and 100x simultaneously
Objective scanner:	<ul style="list-style-type: none"> • Closed loop piezo Objective Scanner for ultra-stable long term spectroscopic laser alignment • Range 30 x 30 x 10 μm^3 • Resolution: 1 nm

OmegaScope Options	
Conductive Unit (Current range 100fA - 10 μA / 3 current ranges (1nA, 100nA and 10 μA) software switchable)	
Liquid Cell / Electrochemical Cell (Liquid exchange capability)	
Temperature control for liquid cell (heating up to 60°C)	
Environmental Chamber	
Humidity control system (Relative humidity range 10-85% / Relative humidity stability $\pm 1\%$)	
Heating Cooling module (from -50°C to +100°C)	
Heating module (heating up to 300°C / Temperature stability 0.1°C)	
Heating module (heating up to 150°C / Temperature stability 0.01°C)	
Combined Shear-force and Normal-force tuning fork holder	
STM holder	
Signal Access Module	

OmegaScope Software	
Omega:	<ul style="list-style-type: none"> • Automatic alignment of registration system • Automatic configuration with preset parameters for standard measuring techniques • Automatic cantilever resonance frequency adjustment • Macro language Lua for programming user functions, scripts, and widgets • Capability to reprogram DSP macro language of the controller in real time without reloading control software • Spring constant calibration (Thermal method)
IAPro:	<ul style="list-style-type: none"> • Process images in coordinate space including making cross-sections, fitting and subtracting of polynomial (up to 12 degrees) surface • FFT processing with the capability to treat images in frequency space including filtering and analysis
Processing:	<ul style="list-style-type: none"> • up to 5000 x 5000 pixel images.

OmegaScope Controller Electronics	
Modular, fully digital, expandable controller	
High speed DSP 300 MHz	
ADC: 20 channels	
High speed 500 kHz 18-bit ADCs for scanner position sensor	
5 MHz frequency range registration system	
2 lock-in amplifiers with 5 MHz frequency range	
6 digital 32-bit generators with 5 MHz frequency range, 0.018 Hz resolution	
7 stepper motors control	
Digital outputs for integration with external equipment	
Analog input/outputs for integration with external equipment	

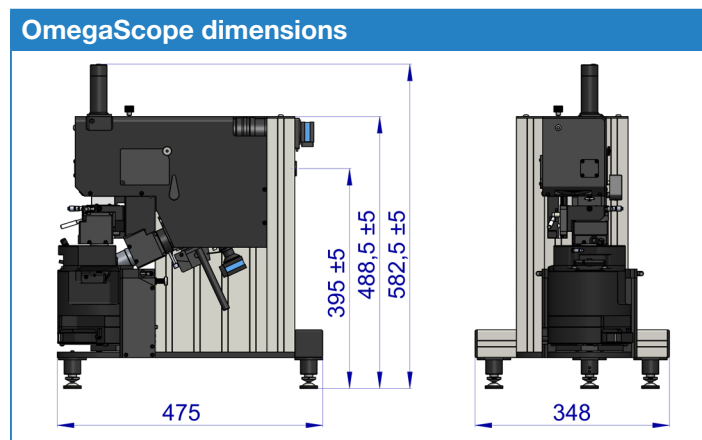

$\lambda = 325-1064\text{nm}$ $P \leq 500\text{mW}$
 VISIBLE AND/OR INVISIBLE LASER RADIATION
 AVOID EXPOSURE TO BEAM
 CLASS 3B LASER PRODUCT



HORIBA
Scientific

中国区授权经销商
 上海亨东仪器有限公司
 工作时间：周一至周五 (8 : 30 - 17 : 30)
 免费热线：400-991-9227
 手机：13661698706
 邮箱：13661698706@139.com
 网址：http://www.shhd17.com